

CM-150

The CM-150 is a ½-inch-diameter (12.7-mm), omnidirectional electret-condenser microphone. It is intended for professional recording, free-field measurement and sound-level measurement.

Because of its pre-aged titanium diaphragm, the CM-150 is extremely stable over a wide range of environmental conditions. The CM-150 has a very flat, wide-range frequency response. The mic is supplied with a proof-of-performance sheet, which shows frequency response and sensitivity. This information can be used to calibrate the microphone. The mic capsule grille fits into a Bruel & Kjaer 4220 pistonphone or similar microphone calibrator.

When used for recording, the CM-150 sounds natural and accurate. It preserves the delicate timbre of acoustic instruments, yet can reproduce all the power of a pipe organ. The off-axis response is also smooth, so any leakage picked up has little coloration.

Self-noise is low, permitting clean recordings — especially with close miking. The mic can handle very loud sounds (127 dB SPL) without distortion. It is protected against static and RFI. The output is balanced, low impedance, which allows long cable runs without hum pickup or high-frequency loss. Powering is by 18-48 volt phantom power.

An included foam windscreen reduces wind noise outdoors.

Architects' and Engineers' Specifications

The microphone shall be a Crown CM-150 or equivalent. It shall be an omnidirectional electret-condenser type powered by 18-48 volt phantom power. Frequency response shall be uniform from 20 Hz to 20,000 Hz. Open-circuit sensitivity shall be 10.5 mV/Pa. Maximum SPL for 3% THD shall be 127 dB with 48-volt phantom power. Self-noise shall be 19 dB SPL A-weighted. Impedance shall be 240 ohms balanced. The mic shall be compatible with ½-inch (12.7 mm) industry standard calibration. The Crown CM-150 is specified.

PROFESSIONAL OMNIDIRECTIONAL CONDENSER MICROPHONE



Specifications

Element: Electret condenser.

Frequency response (typical): 20 Hz to 20 kHz ± 1.5 dB (see Fig. 1).

Polar pattern: Omnidirectional (see Fig. 2)

Impedance: 150 ohms, 240 ohms actual, balanced. Recommended minimum load impedance 1000 ohms.

Open circuit sensitivity (48 volt supply): 10.5 mV/Pa* (-39.5 dB re 1 volt/Pa) nominal.

Power sensitivity: -39.5 dB re 1 mW/Pa.

Equivalent noise level (self-noise): 19 dB SPL typical, A-weighted (0 dB = .0002 dyne/cm²).

S/N ratio: 75 dB at 94 dB SPL.

Maximum SPL for 3% THD: 127 dB with 48V phantom power.

Output connector: 3-pin male XLR type.

Power: 18-48 volt phantom power, positive voltage on pins 2 and 3 with respect to pin 1.

Current drain: 2.7 mA.

Polarity: Positive (inward) pressure on the diaphragm produces positive voltage on pin 2 with respect to pin 3 of the output connector.

Materials: Brass handle, stainless steel mic capsule, titanium diaphragm.

Finish: Satin black handle and chrome mic capsule.

Dimensions: See Fig. 3.

Weight: 4.48 ounces (127 grams).

Included accessories: WS-15 foam wind-screen, carrying pouch, ASA-4 stand adapter and vinyl grille protector.

Optional accessories: Crown PH-4B phantom power supply (4 channels, AC powered). Crown PH-1A phantom power supply (1 channel, battery or AC powered).

*1 pascal = 10 dynes/cm² = 10 microbars = 94 dB SPL.

Fig. 1

Frequency Response

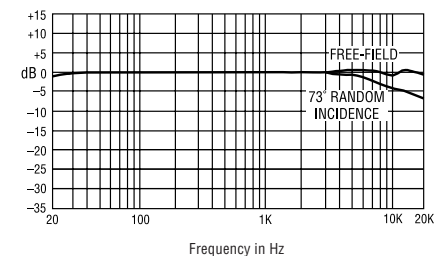
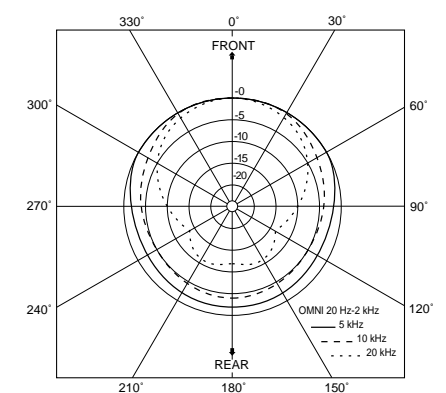
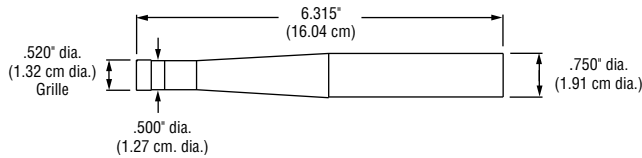

Fig. 2



CM-150

Fig. 3



Sensitivity Changes vs. Phantom-Power Voltage

The CM-150 has different sensitivity at different phantom voltages. If you use phantom powering other than 48 volt, change the printed sensitivity of your unit by the amount shown in the right hand column below.

For example, if the sensitivity on your printout is 11 mV/Pa, and you are using the mic with 24-volt phantom, the correct sensitivity is 11-2.1 or 8.9 mV/Pa.

Phantom	Change in Printout Sensitivity
48 V (6.8K resistors)	0 mV
24 V (1200 ohm resistors)	-2.1 mV
18 V	-2.6 mV
18 V center tap transformer such as in PH-1A	-0.6 mV
12 V (680 ohm resistors)	-3.6 mV

Warranty

Crown professional microphones are guaranteed against malfunction for a period of three years from date of original purchase. Please refer to the enclosed full warranty statement for more detail.

Service

If the microphone fails to work, replace or repair the mic cables, or check the power supply. If service is required, return the microphone in its original packaging to Crown Factory Service, 1718 West Mishawaka Road, Elkhart, Indiana 46517. For further assistance or technical support call 800-342-6939.



A Harman International Company

Crown Audio, Inc.
 P.O. Box 1000
 Elkhart, IN 46515-1000
 TEL: 574-294-8000
 FAX: 574-294-8FAX

©2003 Crown Audio, Inc.
 Specifications subject to change without prior notice.
 Latest information available at www.crownaudio.com.
 Crown® is registered trademark of Crown International, Inc.